

Ordered by:

Changzhou He Jia Solar Energy Co., Ltd.
No. 16, Chingjiao rd, Dongqing town
Changzhou, Jiangsu
CN-213114 Changzhou

Tel. +86 519 8967878
Fax: +86 519 8967868

Test Report No. C908LPEN

Performance test according to EN 12975-2:2006, Paragraph 6

Content:	page
1 Description of Collector.....	2
1.1 Technical Data of the Sample.....	2
1.2 Sketch of Collector.....	3
1.3 Specifications on Elements.....	3
1.4 Photo of Collector	4
1.5 Sketch of Collector Mounting.....	4
2 Test Methods and Results	5
2.1 Test of Thermal Performance	5
2.2 Schematic of the Test Loop	5
2.3 Power Output.....	6
2.4 Incident Angle Factor	9
2.5 Time Constant.....	10
2.6 Effective Thermal Capacity.....	10
2.7 Pressure Drop.....	11
2.8 Observed Failures	12
3 Remarks.....	12

1 Description of Collector

1.1 Technical Data of the Sample

Product information	
Manufacturer	Changzhou He Jia Solar Energy Co., Ltd.
Model	HCA-58/20
Type	Evacuated tube collector
Flow	Heat Pipe
Serial product	Yes
Drawing number	A complete set of technical drawings is filed at the test institute.
Serial number	HJFPB2007-5-28-3-3
Date of manufacture	28.05.2007

Physical parameters	
Gross length	1.990 m
Gross width	1.403 m
Gross height	0.153 m
Gross area	2.792 m ²
Aperture area	1.891 m ²
Absorber area	1.622 m ²
Weight empty	66.5 kg
Fluid capacity	1.2 l

Construction	
Type	Evacuated tube collector
Number of absorber elements	20
Absorber pitch	70.1 mm
Number of hydraulically parallel tubes	1
Number of thermally serial glazings	1
Material of glazing(s)	Borosilicate glass
Thickness of glazing(s)	1.6 mm

Heat transfer fluid (manufacturers' recommendation)	
Type	Water-glycol
Specifications	--

Flow range (manufacturers' recommendation)	
Flow range	72 - 1200 l/h
Rated flow rate	120 l/h

Absorber	
Absorber element	Evacuated double glass tube
Length of absorber element	1725 mm
Width of absorber element	47 mm
Thickness of absorber element	1.6 mm
Coating	Al-N/Al
Flowed through element	Copper pipe/Heat pipe
Joining technique	Heat conducting aluminum sheets
Joining seam	--

Installation	
On tilted roof	Yes
In tilted roof	No
On flat roof	No
On flat roof with stand	Yes
Facade	No

Casing and insulation	
Casing material	Aluminium
Sealing material	Silicone
Insulation material	Glass wool compression-moulded
Thickness (in mm)	40
Aperture dimensions	1.725 m * 0.0548 m * 20

Limitations (manufacturer information)	
Max. temperature	250°C
Max. operating pressure	6 bar
Other	--

Remarks on collector design	
--	

Test schedule	
Test procedure	EN12975:2006, Outdoor test
Sample received	21.09.2007
Start of test	16.10.2007
End of test	20.02.2008

1.2 Sketch of Collector

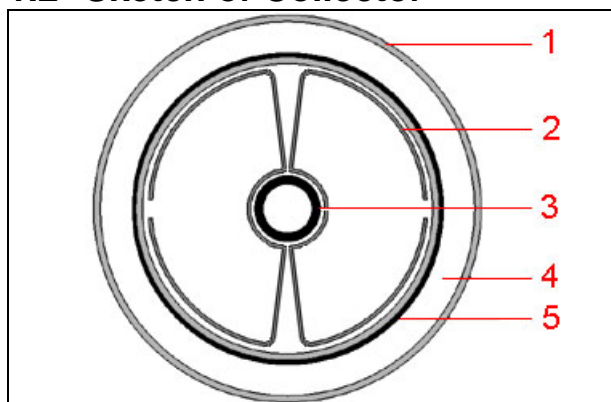

1.3 Specifications on Elements

1	Glazing	
	Material:	Borosilicate glass
	Thickness [mm]:	1.6
2	Heat-conducting metal sheet	
	Description:	Aluminum
3	Heat pipe	
	Description:	Copper
4	Vacuum	
5	Absorber	
	Absorber element:	Evacuated double glass tube
	Flow-through element:	Copper pipe/Heat pipe
	Length of element [mm]:	1725
	Width of element [mm]:	47
	Flow type:	Serial
	Joining technique:	Heat conducting aluminum sheets
5	Absorber coating	
	Description:	Al-N/Al
	Manufacturing process:	Magnetron Sputter CVD

1.4 Photo of Collector



1.5 Sketch of Collector Mounting

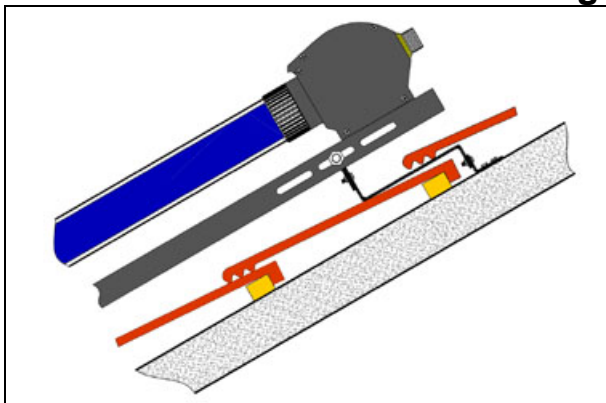

2 Test Methods and Results

2.1 Test of Thermal Performance

Tests carried out according to EN 12975-2: 2006.

Deviations from this standard are indicated by the same formatting that is used for this clause. The reasons for the deviations are mentioned.

2.2 Schematic of the Test Loop

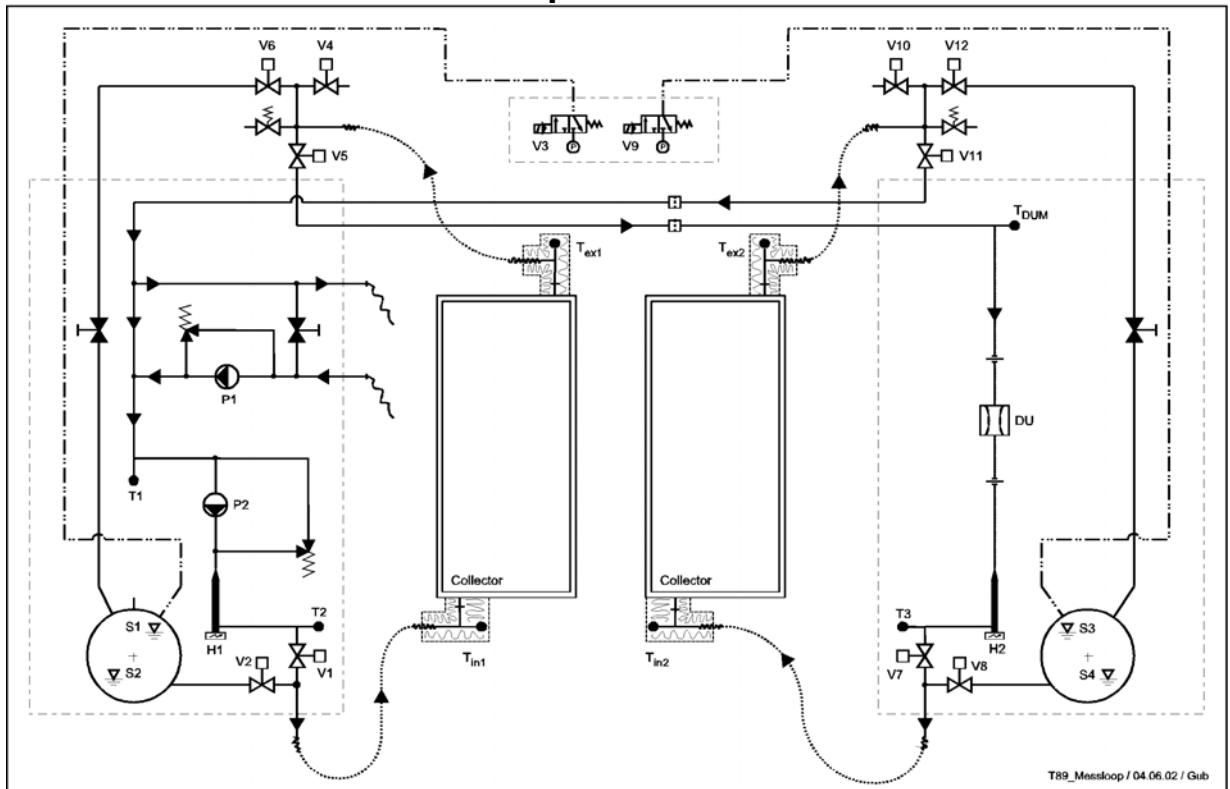

Fig. 2.1: Test loop for efficiency measurements.

2.3 Power Output

2.3.1 General

Flow rate during test	120.0 l/h
Fluid for tests	33.3 Vol-% ethylene glycol
Test method	stationary (steady state)
Geographical position of test site	47.2°N / 8.8°O, 417 m NN
Collector tilt angle	tracked (45±5)°
Collector azimuth angle	tracked (0±48)°
Definition of efficiency	$\eta = \dot{Q}/A \cdot G$
Thermal output power of collector	\dot{Q}
Reference area	A
Solar irradiance	G
Solar irradiance on reference area	A·G
Efficiency equation	$\eta = \eta_0 - a_1 \cdot T_m^* - a_2 \cdot G \cdot T_m^{*2}$
Temperature at collector inlet	T_{in}
Temperature at collector outlet	T_{ex}
Ambient temperature	T_a
Mean collector temperature	$T_m = (T_{in} + T_{ex})/2$
Reduced collector temperature	$T_m^* = (T_m - T_a)/G$
Solar irradiance for efficiency diagrams	G = 800 W/m ²

2.3.2 Power output per collector unit

2.3.2.1 Peak power

Peak power W_{peak} per collector unit for normal incident irradiation of 1000 Wm^{-2} .

$$W_{\text{peak}} = 1236 \text{ [W]}$$

2.3.2.2 Diagram

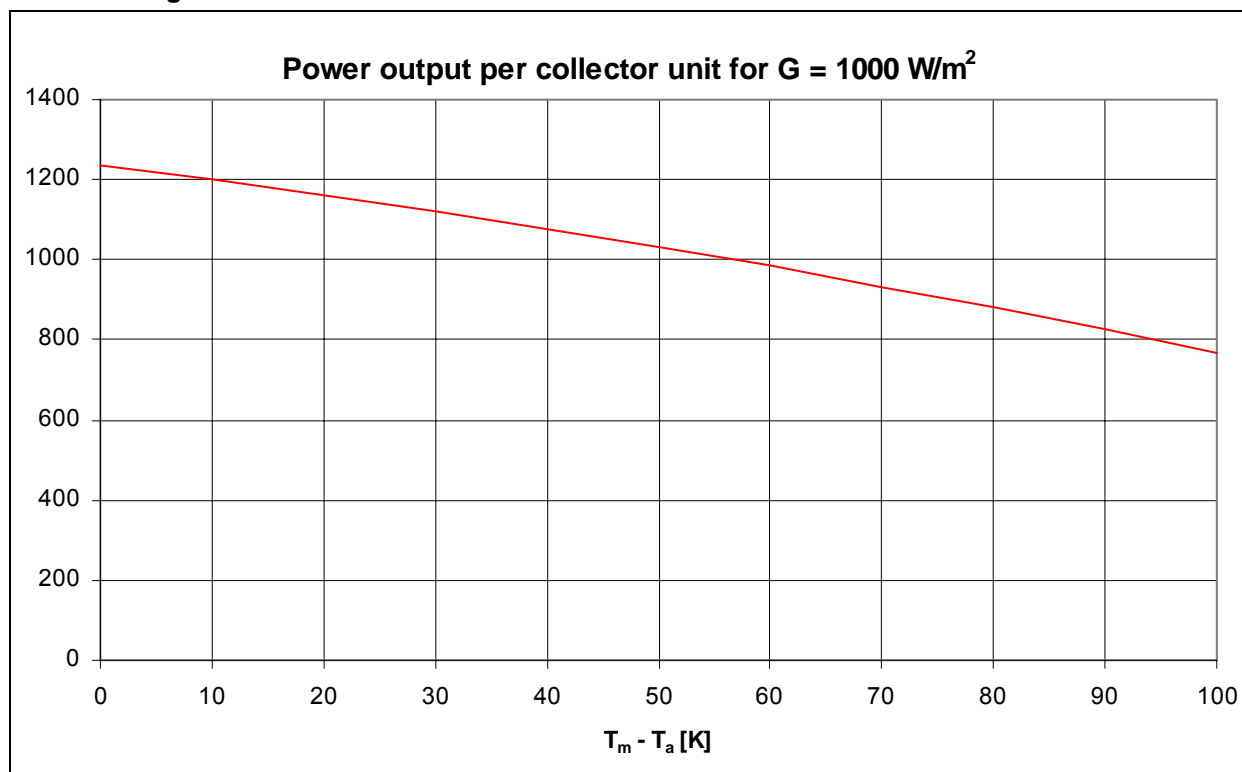

Fig. 2.2: Power output per collector unit at irradiance $G = 1000 \text{ W/m}^2$

2.3.2.3 Power output per collector unit

$T_m - T_a$	Global irradiance G		
	G=400 W/m ²	G=700 W/m ²	G=1000 W/m ²
10 K	459 W	830 W	1200 W
30 K	380 W	751 W	1122 W
50 K	291 W	662 W	1033 W

2.3.3 Efficiency curve

The efficiency curves with reference to the absorber-, aperture- and gross areas are indicated in addition to the requirements of the norm.

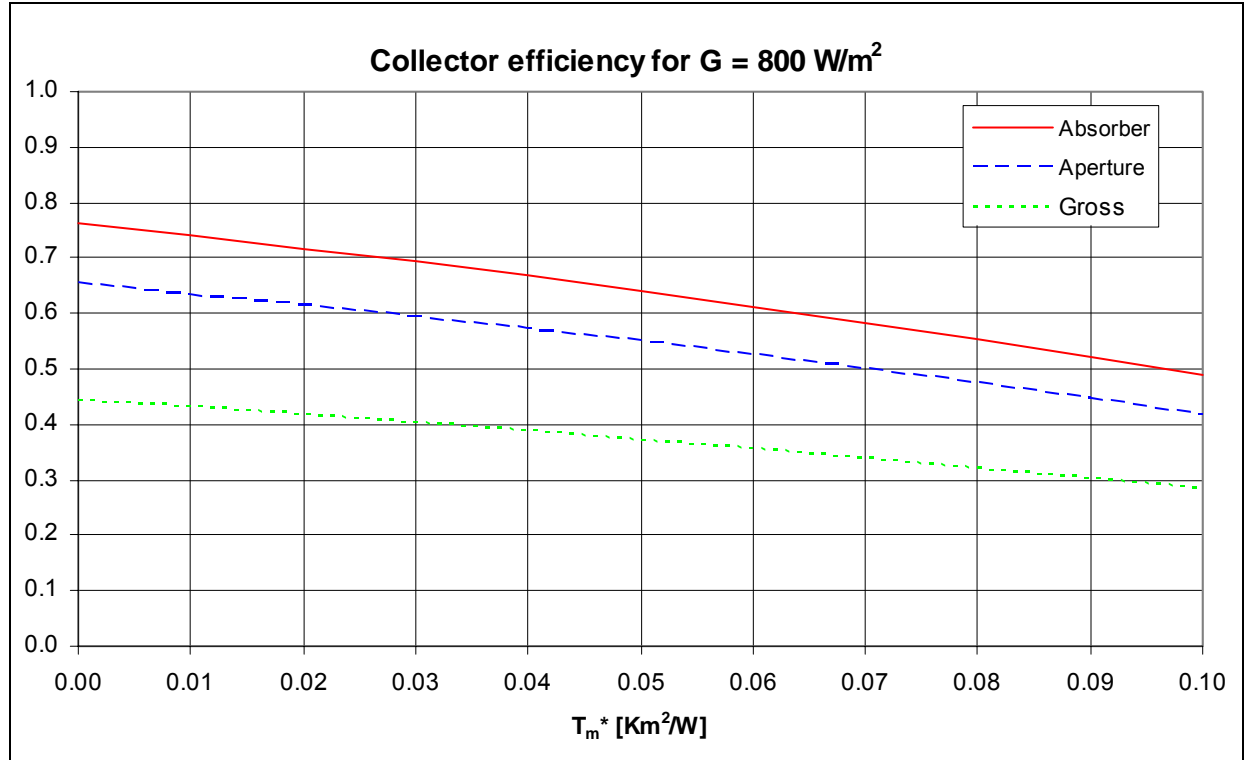

Fig. 2.3: Efficiency diagram for G = 800 W/m²

2.3.3.1 Parameters for efficiency equation

Reference area	Absorber area	Aperture area	Gross area
η_0 (-)	0.762	0.654	0.443
a_1 (W/m²K)	2.12	1.82	1.23
a_2 (W/m²K²)	0.0077	0.0066	0.0045

From repetitive measurements of a reference collector, we estimate the following dispersion for the efficiency measurement (standard deviation of the mean, multiplied with a coverage factor 2):

- At $T_m^*=0.02$: 0.27 Efficiency-%,
- at $T_m^*=0.05$: 0.44 Efficiency-%,
- at $T_m^*=0.08$: 0.62 Efficiency-%.

2.4 Incident Angle Factor

2.4.1 Table of the Incidence Angle Modifier (IAM)

	0°	10°	20°	30°	40°	50°	60°	70°	80°	90°
K_{Θ} (longitudinal)	1.00	1.00	1.00	0.99	0.97	0.94	0.87	0.73	0.47	0.00
K_{Θ} (transversal)	1.00	1.00	1.04	1.15	1.30	1.36	1.34	1.11	0.62	0.00

2.4.2 Diagram of the Incidence Angle Modifier

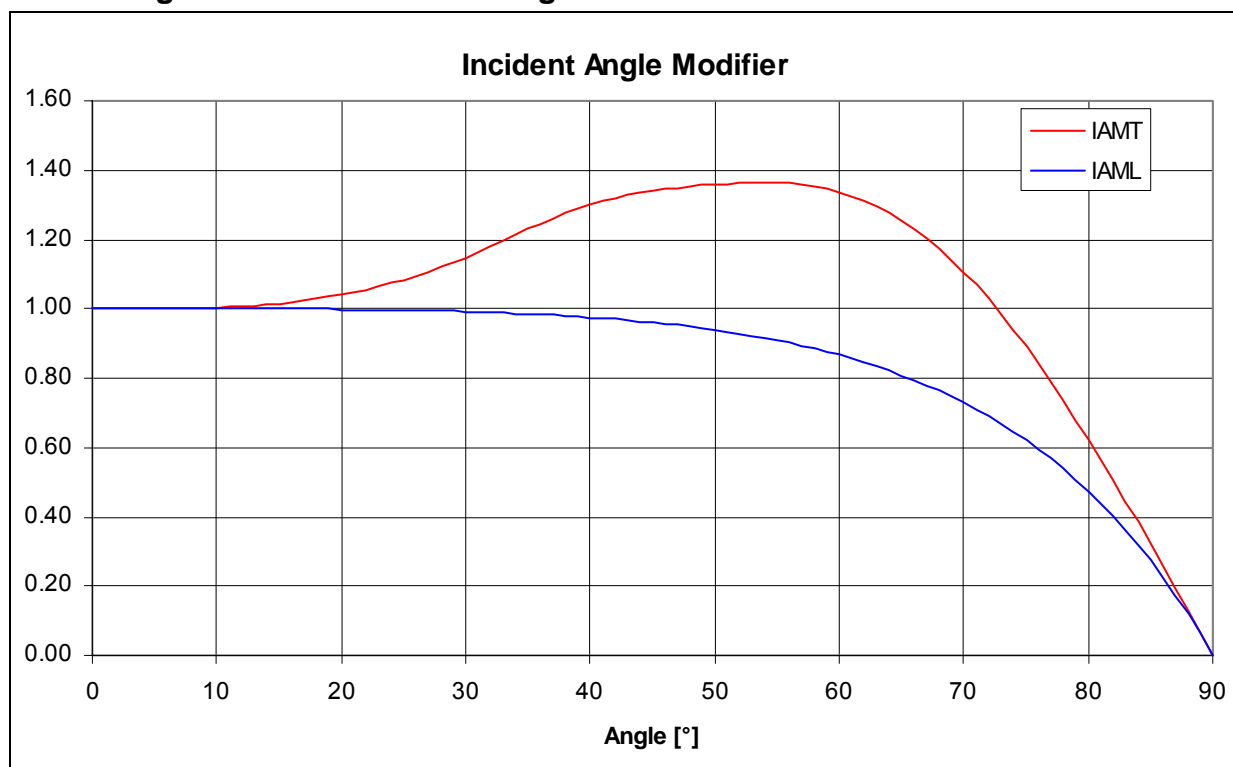

Fig. 2.4: Incident angle modifiers

2.5 Time Constant

$\tau_C = 862 \text{ s}$

2.6 Effective Thermal Capacity

2.6.1 Determination according to EN12975-2:2006, Annex G.3

Determination based on transient behaviour of the collector.

$C_{\text{eff,G3}} = 205.3 \text{ kJ/K}$ (Effective thermal capacity of collector filled with fluid)

Additional information: The thermal capacity was measured with the properties of „Antifrogen N“. For other fluids, the thermal capacity is calculated as follows:

$C_{\text{eff,G3}} = 1.2 \text{ l} * \text{density} * \text{specific heat capacity of fluid} + 200.9 \text{ kJ/K}$

2.6.2 Determination according to EN12975-2:2006, Section 6.1.6.2

Estimation based on material properties.

$C_{\text{eff,6162}} = 26.9 \text{ kJ/K}$ (Effective thermal capacity of collector filled with fluid)

Additional information: The thermal capacity was measured with the properties of „Antifrogen N“. For other fluids, the thermal capacity is calculated as follows:

$C_{\text{eff,6162}} = 1.2 \text{ l} * \text{density} * \text{specific heat capacity of fluid} + 22.5 \text{ kJ/K}$

2.7 Pressure Drop

2.7.1 Diagram

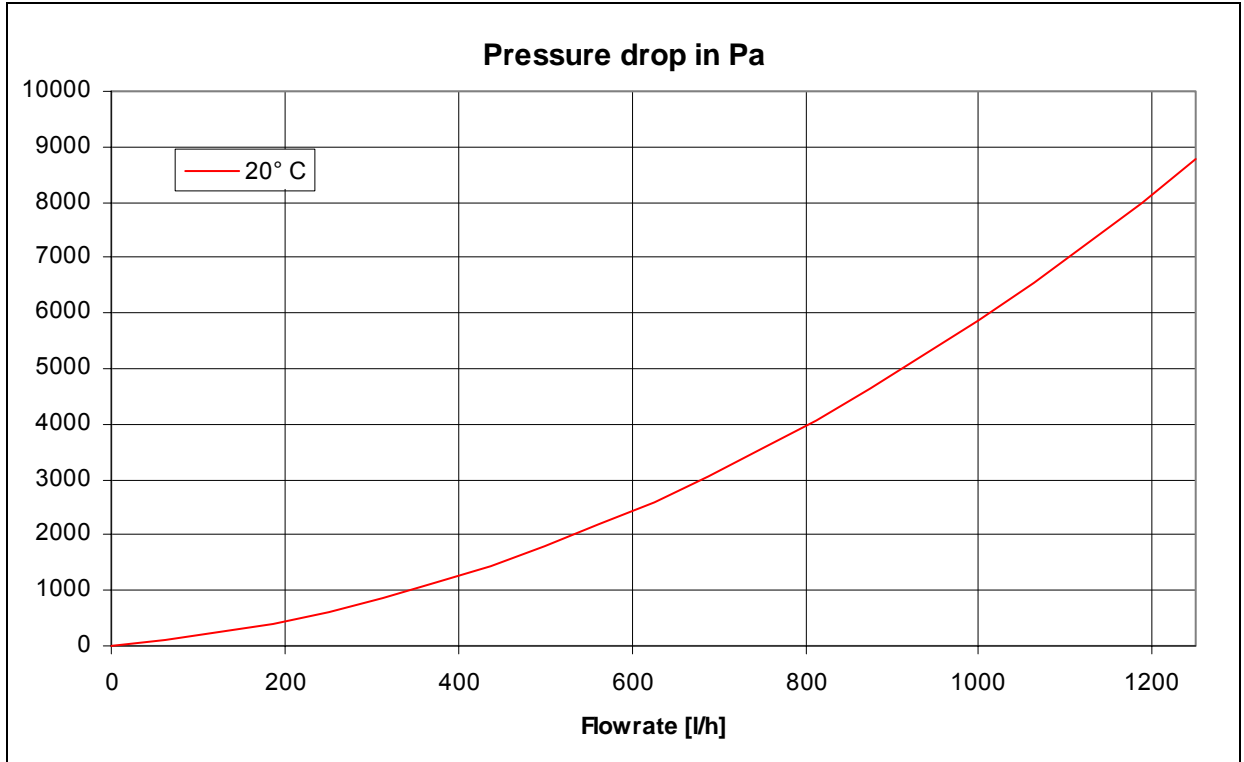

Fig. 2.5: Pressure drop as a function of volume flowrate

2.7.2 Pressure drop at rated flowrate

Conditions:

$T_m = 20^\circ\text{C}$ and $dV/dt = 120 \text{ l/h}$

$\Delta p = 224 \text{ Pa}$

2.7.3 Table of pressure drop data in Pa

Conditions:

$T_m = 20^\circ\text{C}$

Flow rate [l/h]	0	250	500	750	1000	1250
Pressure drop [Pa]	0	615	1800	3555	5878	8771

2.8 Observed Failures

Details about failures that are rated as major failures according to paragraph 5.3.1 of EN12975-1:2006.

Absorber leakage or such deformation that permanent contact between absorber and cover is established.	Passed
Breaking or permanent deformation of cover or cover fixing.	Passed
Breaking or permanent deformation of collector fixing points or collector box.	Passed
Loss of vacuum or low pressure (applicable for vacuum or subatmospheric collectors)	Passed
Accumulation of humidity in form of condensate on the inside of the transparent cover of the collector exceeding 10% of the aperture area	Passed

No major failures according to paragraph 5.3.1 of EN12975-1:2006 were found for this collector.

3 Remarks

This report must not be copied except in full.
The test methods applied fulfil the requirements of EN12975:2006.
The test results only refer to the tested collector sample.
This test report is made according to the requirements of EN12975:2006.
This test report fulfils the requirements of ISO17025.

Rapperswil, 06.06.2008



Dr. Andreas Bohren
Head of SPF Testing



Dipl.-Ing. Walter Gubler
Test engineer